



MANUAL – VARITHERM VBD FIELD INSTALLATION

DISIO DISPLAY

Adjuster

v100 – Issue Date: 04/05/24

© 2024 Price Industries Limited. All rights reserved.

price | VAV
DIFFUSERS

DISIO Display - Adjuster

INSTRUCTIONS FOR FIELD ASSEMBLY

Models: VPD

NOTE: The Disio Display Adjuster uses a Master and Secondary diffuser wiring scheme. These instructions are for installing the diffuser kit onto the diffuser (Master and/or Secondary). For installation and wiring of the diffuser in the ceiling, please see the Disio Display Adjuster Manual.

QTY	Part
1	Terminal box complete with screw terminal block and pig tail
2	Pop rivets
2	Grommets
2	Element Heaters
2	Shrink Tube 1in

1. Drill a 5/16 in. hole in the top of the backpan on the same side as the thermostats (see Figure 1).
 2. Position the terminal box over the 5/16 in. hole on the top of the backpan (see Figure 2).
 3. Drill holes for screws or rivets and screw or rivet the terminal box onto the backpan.
 4. Insert the grommet in the 5/16 in. hole in the backpan/terminal box.
 5. Unlatch the hinged appearance panel.
 6. Insert grommet into the hole in the diffusion plate behind the appearance panel clip bracket (see Figure 3).
 7. Adjust the cooling (and heating) thermostat set point to 76°F/24°C.
- CAUTION:** For proper operation of the Disio Wall Adjuster, the diffuser set point(s) must remain at 76°F/24°C.
8. Prepare resistance heaters following Heater Sub-Assembly Instructions (attached).

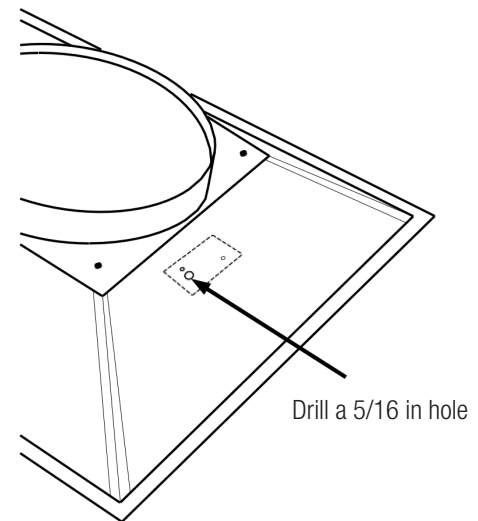

Fig. 1

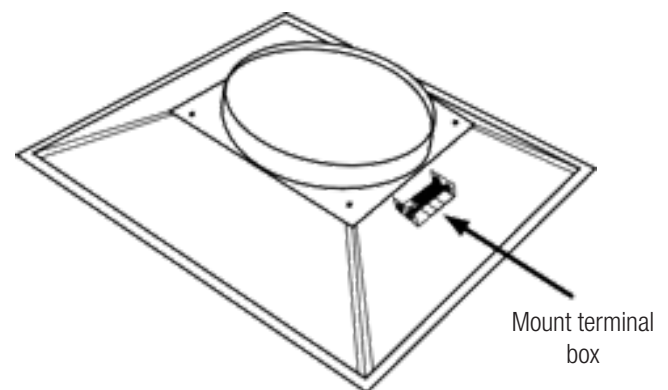

Fig. 2

DISIO Display - Adjuster

INSTRUCTIONS FOR FIELD ASSEMBLY

9. Slip shrink band and heater over the cooling thermostat. Locate the space between the ends of the heater at the bottom of the thermostat (where the heat will be applied to the shrink band). One edge should be against the hub of the thermostat. Heat the shrink band with a hair dryer until the band is tight. (Repeat for heating thermostat.)

10. Route the wires through the 1/4 in. hole in the scoop, through the 5/16 in. hole in the backpan and into the terminal box (see Figure 4 and 5).

11. Connect the red wire(s) to terminal 3 and the black wire(s) to terminal 4 (see Figure 5).

Make the connections on the side opposite the label leaving the label side open for when the diffuser is installed in the ceiling.

12. Fold up and latch the appearance panel.

If wiring a Secondary diffuser or the terminal box has been factory wired with a pigtail with 10 pin quick connector (see Figure 6 and skip steps 13, 14 and 15).

NOTE: The pigtail with 10 pin quick connector is ONLY required on a Master diffuser.

13. Route the open end of the pigtail with 10 pin connector through the grommet opposite the label on the screw terminal side (see Figure 7).

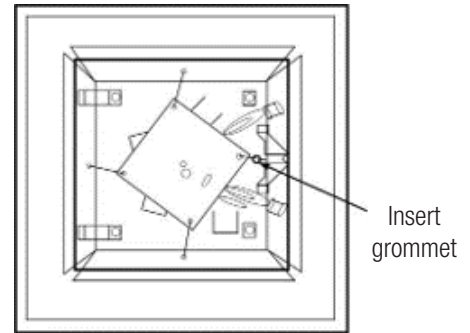

Fig. 3

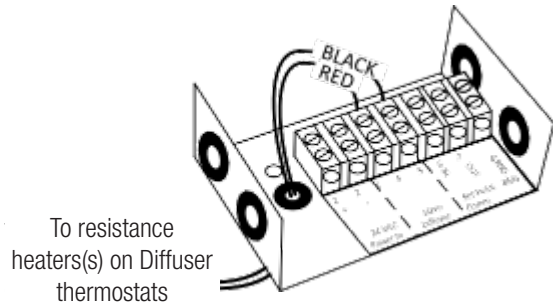

Fig. 4

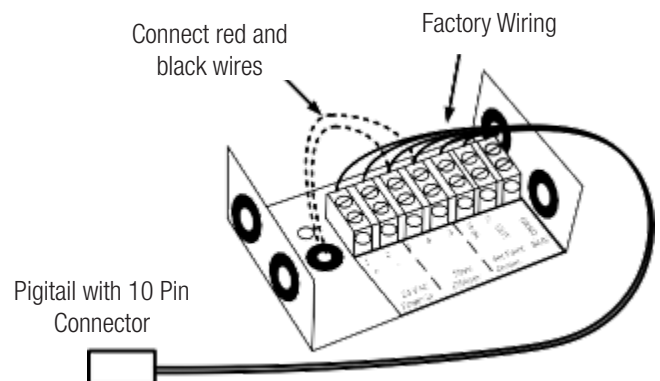

Fig. 5

DISIO Display - Adjuster

INSTRUCTIONS FOR FIELD ASSEMBLY

14. Connect the wires of the pigtail with 10 pin connector (see Figure 7):

Wire	Screw Terminal
Orange	1
Brown	2
Blue	3
Green	4
Black	5
Purple	6
White	7
Yellow	Not Used
Red	Not Used
Grey	Not Used

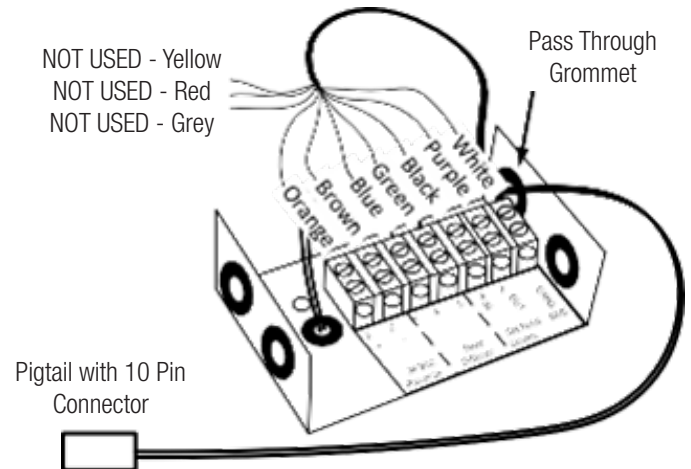

Fig. 6

15. Make the connections on the side opposite the label leaving the label side open for when the diffuser is installed in the ceiling.

16. Fit the cover onto the terminal box.

17. Diffuser is ready for installation into the ceiling.

For installation and wiring of the diffuser in the ceiling and maintenance instructions please see the Disio Display Adjuster Manual.

DISIO Display - Adjuster

INSTRUCTIONS FOR FIELD ASSEMBLY

Resistance Heater Sub-Assembly Instructions

1. With the flag away and pointing upwards

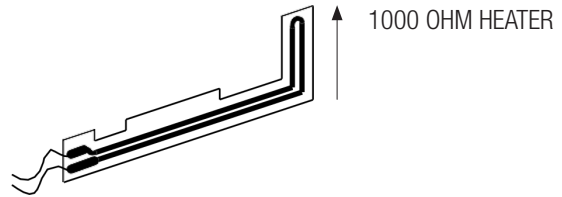

2. Curl the flag toward the right.

Do not curl toward the left as it will change the resistance.

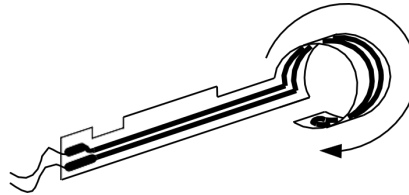

3. Slip the shrink band over the curled flag.

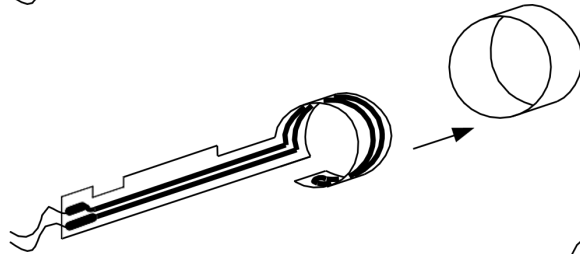

4. Slide the shrink band/flag combination over the thermostat flush with the hub of the thermostat.

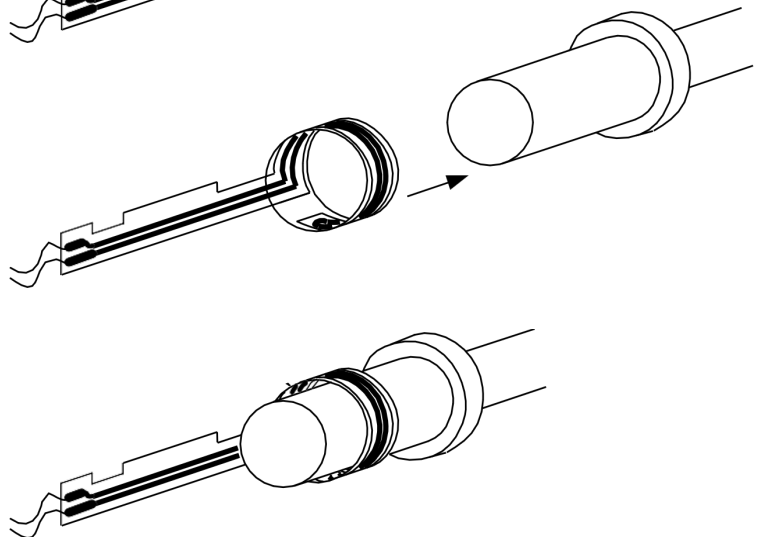

This document contains the most current product information as of this printing.
For the most up-to-date product information please go to priceindustries.com.

© 2024 Price Industries Limited. All rights reserved.

